

Product category: R-stud 30 mil Drywall Stud
Product name: 400RS162-30 50 Ksi G60
4" x 1-5/8" R-stud

Coating: G60
Color coding: White

Geometric Properties

Web depth	4.000 in	Weight	0.79436 lb/ft
Flange width	1.625 in	Web opening width	9-13/16 in
Stiffening lip	0.310 in	Web opening length	2-3/16 in
Design thickness	0.030 in	Minimum thickness	0.0296 in
Yield stress, Fy	50 Ksi		

Gross Section Properties of Full Section, Strong Axis*

Cross sectional area (A)	0.23363 in ²
Moment of inertia (Ix)	0.62994 in ⁴
Radius of gyration (Rx, r1)	1.6557 in
Moment of inertia (Iy)	0.07426 in ⁴
Radius of gyration (Ry, r2)	0.5638 in
Max bending moment Ix (Maxo)	8.0026 k-in
Max bending moment Iy (Mayo)	2.1250 k-in
Allowable shear force in web (Vax)	1.6004 k

Tension/Compression Properties*

Warping constant (Cw)	0.013131 in ⁶
Distance from shear center to neutral axis (Xo)	-0.9618-in
Radii of gyration (Ro)	1.9961 in
Torsional flexural constant (Beta)	FEA-in ⁴
Compression Pao (max)	5.0199 k
Tension Tao (Ta)	7.2776 k
Unbraced Length (Lu)	Full / Non-braced
Fully Braced Strength (CFS) *CFS result	

Notes:

- Calculated properties are based on AISI S100-12, North American Specifications for Cold-Formed Steel Structure Members and ICC-ES AC46-2015, Acceptance Criteria for Cold-Formed Steel Framing Members.
- Effective properties herein incorporate the increased strength from cold working of the steel while forming. We only use 50Ksi coils.
- Tabulated gross properties, including torsional properties, are based on the added cross section properties of the web openings. R-studs do not have punch-outs.
- Allowable moment includes cold work of forming.
- Allowable moment is taken as the lowest value based on local or distortional buckling. Distortional buckling strength is based on K-phi=0
- For deflection calculations, use the effective moment of inertia.
- Web openings are every 12 inches and are 9-13/16 inches long with flanges being 0.94 inches tall and corners of the web openings enhanced.

Sustainability: R-stud sources its steel coils from American Suppliers, such as US Steel and NUCOR's California Steel Industries for rolling in our manufacturing facilities. Our coils contain approximately 34.2% recycled steel. Approximately 19.8% is Post-consumer content, while Pre-consumer content is approximately 14.4%. R-studs are listed as "Red List Free" by the International Living Future Institute. **R-stud can provide a significant reduction of Embodied Carbon over comparable standard steel studs.** Steel is one of the most sustainable building materials in the world. It is recycled content, recyclable, durable, safe, zinc-coated, dimensionally stable and strong, as well as not susceptible to rot, termites, or mold.

Supported Documentation

- 2016 AISI - ASD, LRFD, and LSD
- 2012 AISI - ASD, LRFD, and LSD
- 2010 AISI - ASD, LRFD, and LSD
- 2007 AISI - ASD, LRFD, and LSD
- 2004 AISI - ASD, LRFD, and LSD
- 2001 AISI - ASD, LRFD, and LSD
- 1999 AISI - ASD and LRFD & 2002 ASCE - ASD and LRFD (stainless steel)

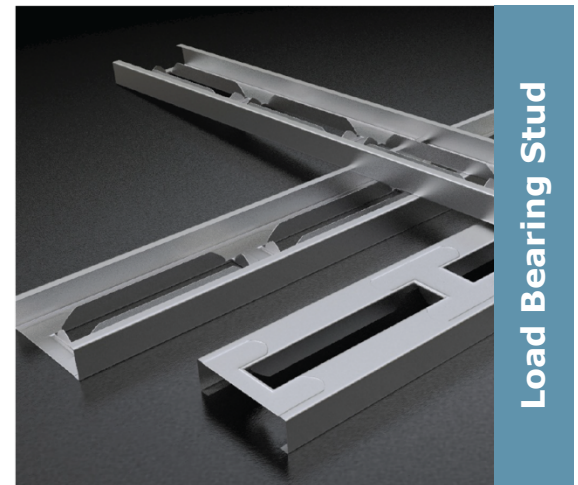

Load Bearing Stud

Web openings (not punch-outs) formed from web every 12 in. with Stamping at bridge every 12 in.

ASTM & Code Standards:

- ✓ ATI/Intertek CCRR 1073
- ✓ IBC 2012 Compliant
- ✓ AISI S-100 & S220-11
- ✓ ASTM E119, E72, E90
- ✓ ASTM AC86, C645, & C745
- ✓ UL 263
- ✓ US, Canadian, and International Patents Issued

Project Information

Name:
Address:

Contractor Information

Name:
Contact:
Phone:
Fax:

Architect Information

Name:
Contact:
Phone:
Fax:



Product Data Sheet

info@rstud.com
800-971-8095
www.rstud.com

Project Information

Name:
Address:

Contractor Information

Name:
Contact:
Phone:
Fax:

Architect Information

Name:
Contact:
Phone:
Fax:

Product category: R-stud 30 mil Drywall Stud
Product name: 400RS162-30 50Ksi G60
4" x 1-5/8" R-Stud

Limiting Wall Heights

Spacing (inches)	5 psf			7.5 psf			10 psf		
	L/120	L/240	L/360	L/120	L/240	L/360	L/120	L/240	L/360
16	26'4"	20'11"	18'3"	23'1"	18'3"	15'11"	20'11"	16'6"	14'6"
24	23'8"	18'9"	15'11"	20'9"	15'11"	13'10"	18'3"	13'11"	12'8"

Table Notes:

- Allowable composite limiting heights were determined from AC86-2012 testing by Intertek Testing / Architectural Testing, Inc.
- The composite limiting heights tables provided above are based on a single layer of Type X gypsum board from the following manufacturers, American, CertainTeed, Georgia Pacific, National, PABCO, and USG.
- The gypsum is to be applied full height in the vertical orientation to each stud flange and installed in accordance with ASTM C754-2004 using a minimum of No. 6 Type S Drywall spaced as listed below:
 - Screws spaced a minimum of 16 inches on-center to framing members spaced at 12 or 16 inches on-center.
 - Screws spaced a minimum of 12 inches on-center to framing members spaced at 24 inches on-center.
- No fasteners are required for attaching the stud to the track except as detailed in ASTM C754-2008.

Profile

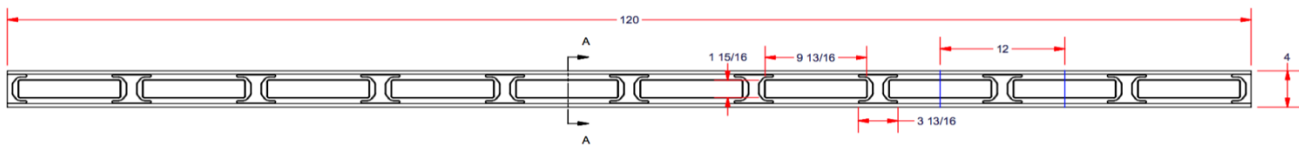
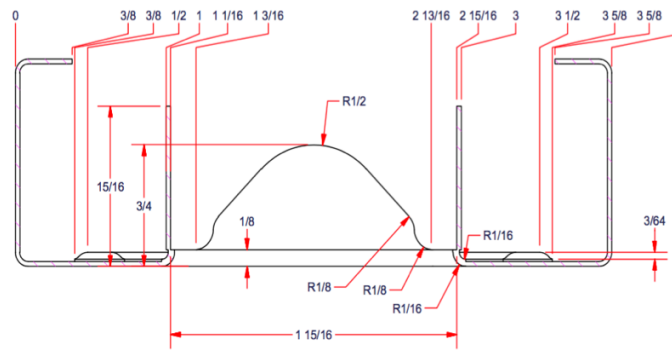

Project Information

Name:
Address:

Contractor Information

Name:
Contact:
Phone:
Fax:

Architect Information

Name:
Contact:
Phone:
Fax: