

**Product category:** R-stud 18 mil Drywall Stud  
**Product name:** 362RS162-18 50 Ksi G60  
3-5/8" x 1-5/8" R-stud

Coating: G60  
Color coding: Clear

### Geometric Properties

Web depth	3.625 in	Weight	0.479 lb/ft
Flange width	1.625 in	Web opening width	2.0 in
Stiffening lip	0.500 in	Web opening length	9-13/16 in
Design thickness	0.0188 in	Minimum thickness	0.0179 in
Yield stress, Fy	50 Ksi		

### Gross Section Properties of Full Section, Strong Axis\*

Cross sectional area (A)	0.33668 in <sup>2</sup>
Moment of inertia (Ix)	0.7567 in <sup>4</sup>
Radius of gyration (Rx, r1)	1.4991 in
Moment of inertia (Iy)	0.1042 in <sup>4</sup>
Radius of gyration (Ry, r2)	0.5565 in
Max bending moment Ix (Maxo)	10.233 k-in
Max bending moment Iy (Mayo)	3.871 k-in
Allowable shear force in web (Vax)	2.826 k

### Tension/Compression Properties\*

Warping constant (Cw)	0.016409 in <sup>6</sup>
Distance from shear center to neutral axis (Xo)	-0.9597 in
Radii of gyration (Ro)	1.8649 in
Torsional flexural constant (J, Beta)	FEA-J = 0.000827 in <sup>4</sup>
Compression Pao(max)	7.564 k
Tension Tao (Ta)	11.784 k
Unbraced Length (Lu)	Full / Non-braced
Fully Braced Strength (CFS) *CFS result	

### Notes:

- Calculated properties are based on AISI S100-12, North American Specifications for Cold-Formed Steel Structure Members and ICC-ES AC46-2015, Acceptance Criteria for Cold-Formed Steel Framing Members.
- Effective properties herein incorporate the increased strength from cold working of the steel while forming. We only use 50Ksi coils.
- Tabulated gross properties, including torsional properties, are based on the added cross section properties of the web openings. R-studs do not have punch-outs.
- Allowable moment includes cold work of forming.
- Allowable moment is taken as the lowest value based on local or distortional buckling. Distortional buckling strength is based on K-phi=0
- For deflection calculations, use the effective moment of inertia.
- Web openings are every 12 inches and are 9-13/16 inches long with flanges being 0.94 inches tall and corners of the web openings enhanced.

**Sustainability: R-stud** sources its steel coils from American Suppliers, such as US Steel and NUCOR's California Steel Industries for rolling in our manufacturing facilities. Our coils contain approximately 34.2% recycled steel. Approximately 19.8% is Post-consumer content, while Pre-consumer content is approximately 14.4%. R-studs are listed as "Red List Free" by the International Living Future Institute. **R-stud can provide a significant reduction of Embodied Carbon over comparable standard steel studs** Steel is one of the most sustainable building materials in the world. It is recycled content, recyclable, durable, safe, zinc-coated, dimensionally stable and strong, as well as not susceptible to rot, termites, or mold.

### Supported Documentation

- 2016 AISI - ASD, LRFD, and LSD
- 2012 AISI - ASD, LRFD, and LSD
- 2010 AISI - ASD, LRFD, and LSD
- 2007 AISI - ASD, LRFD, and LSD
- 2004 AISI - ASD, LRFD, and LSD
- 2001 AISI - ASD, LRFD, and LSD
- 1999 AISI - ASD and LRFD & 2002 ASCE - ASD and LRFD (stainless steel)

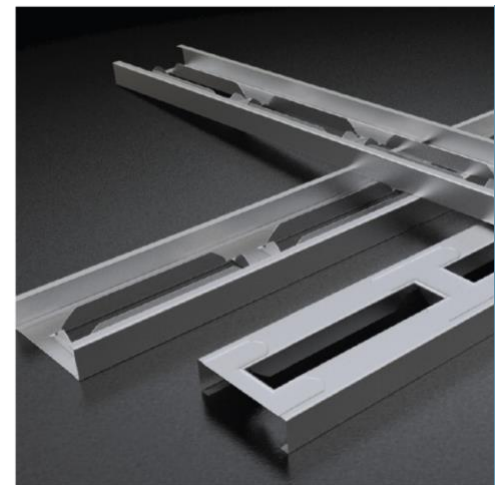

Drywall Stud

Web openings (not punch-outs) formed from web every 12 in. with Stamping at bridge every 12 in.

### ASTM & Code Standards:

- ✓ ATI/Intertek CCRR 1073
- ✓ IBC 2012 Compliant
- ✓ AISI S-100 & S220-11
- ✓ ASTM E119, E72, E90
- ✓ ASTM AC86, C645, & C745
- ✓ UL 263
- ✓ US, Canadian, and International Patents Issued

### Project Information

Name:  
Address:

### Contractor Information

Name:  
Contact:  
Phone:  
Fax:

### Architect Information

Name:  
Contact:  
Phone:  
Fax:

**Product category:** R-stud 18 mil Drywall Stud  
**Product name:** 362RS162-18 50Ksi G60  
3-5/8" x 1-5/8" R-stud

### Limiting Wall Heights

Spacing (inches)	5 psf			7.5 psf			10 psf		
	L/120	L/240	L/360	L/120	L/240	L/360	L/120	L/240	L/360
16	19'- 9"	15"- 8"	13'- 9"	17'-3"	13'-9"	12'-0"	15'-8"	12"-6"	10"-11"
24	17"-3"	13"-9"	12'-0"	15'-1"	13'-0"	10'-6"	13'-9"	10'-11"	9'-6"

- Table Notes:**
- Allowable composite limiting heights were determined from AC86-2012 testing by Intertek Testing / Architectural Testing, Inc.
  - The composite limiting heights tables provided above are based on a single layer of Type X gypsum board from the following manufacturers, American, CertainTeed, Georgia Pacific, National, PABCO, and USG.
  - The gypsum is to be applied full height in the vertical orientation to each stud flange and installed in accordance with ASTM C754-2004 using a minimum of No. 6 Type S Drywall spaced as listed below:
    - Screws spaced a minimum of 16 inches on-center to framing members spaced at 12 or 16 inches on-center.
    - Screws spaced a minimum of 12 inches on-center to framing members spaced at 24 inches on-center.
  - No fasteners are required for attaching the stud to the track except as detailed in ASTM C754-2008.

### Profile

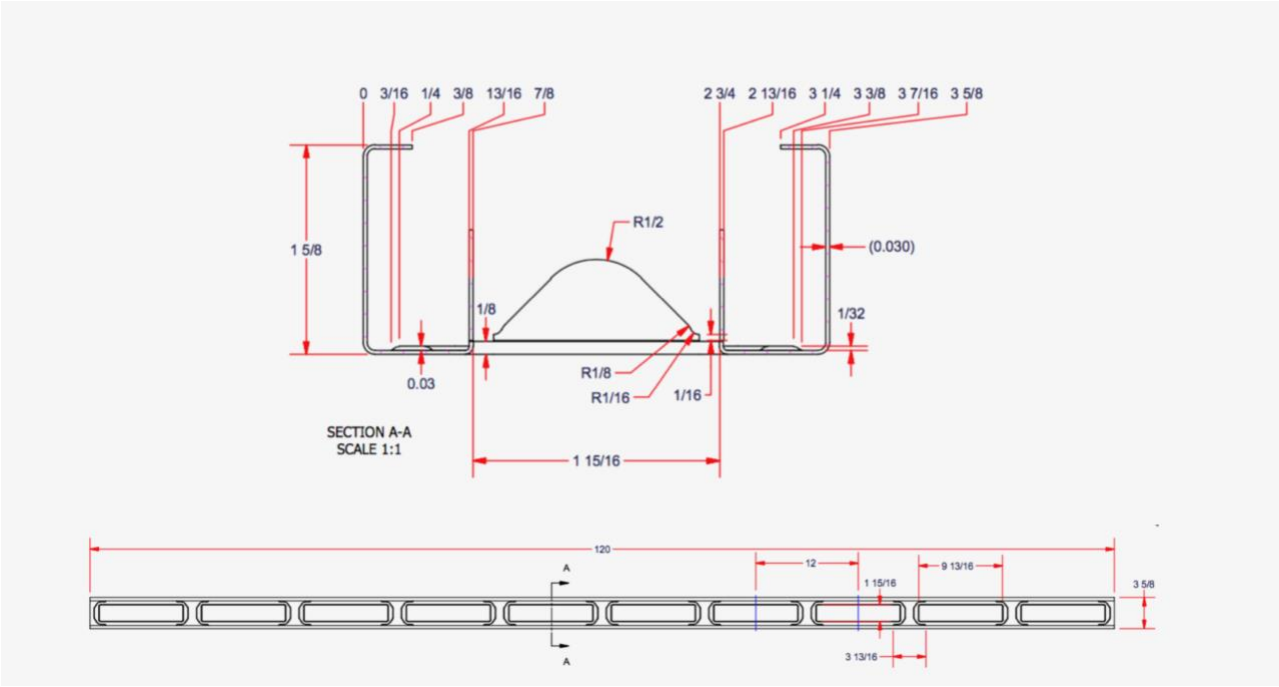

Project Information	Contractor Information	Architect Information
Name:	Name:	Name:
Address:	Contact:	Contact:
	Phone:	Phone:
	Fax:	Fax: