



info@rstud.com
877-289-0705
www.rstud.com

Product Data Sheet

U.S. Patent # US7866112
U.S. Patent # US7743578
U.S. Patent # US8424266

Product category: R-stud 19 mil Drywall Stud
Product name: 400RS162-19 50Ksi G60
4" x 1-5/8" R-stud

Coating: G60
Color coding: None

Geometric Properties

Web depth	4.000 in	Weight	0.4891 lb/ft
Flange width	1.625 in	Web opening length	9-13/16 in
Stiffening lip	0.500 in	Web opening width	2-3/16 in
Design thickness	0.0202 in	Minimum thickness	0.0190 in
Yield stress, Fy	50 Ksi		

Gross Section Properties of Full Section, Strong Axis*

Cross sectional area (A)	0.14385 in ²
Moment of inertia (Ix)	0.3899 in ⁴
Radius of gyration (Rx, r1)	1.6464 in
Moment of inertia (Iy)	0.0459 in ⁴
Radius of gyration (Ry, r2)	0.5649 in
Max bending moment Ix (Maxo)	4.5304 k-in
Max bending moment Iy (Mayo)	1.3379 k-in
Allowable shear force in web (Vax)	0.7307 k

Tension/Compression Properties*

Warping constant (Cw)	0.0093277 in ⁶
Distance from shear center to neutral axis (Xo)	-1.0186 in
Radii of gyration (Ro)	2.0168 in
Torsional flexural constant (Beta)	FEA-in ⁴
Compression Pao(max)	2.8309 k
Tension Tao (Ta)	6.0347 k
Unbraced Length (Lu)	Full / Non-braced
Fully Braced Strength (CFS) *CFS result	

Notes:

- Calculated properties are based on AISI S100-12, North American Specifications for Cold-Formed Steel Structure Members and ICC-ES AC46-2012, Acceptance Criteria for Cold-Formed Steel Framing Members.
- Effective properties herein incorporate the increased strength from cold working of the steel while forming. We only use 50Ksi coils.
- Tabulated gross properties, including torsional properties, are based on the added cross section properties of the web openings. R-studs do not have punch-outs.
- Allowable moment includes cold work of forming.
- Allowable moment is taken as the lowest value based on local or distortional buckling. Distortional buckling strength is based on K-phi=0
- For deflection calculations, use the effective moment of inertia.
- Web openings are every 12 inches and are 9-13/16 inches long with flanges being 0.94 inches tall and corners of the web openings enhanced.

Sustainability: R-stud sources its steel coils from USS-POSCO in Pittsburg, California for rolling in our manufacturing facility in Donald, Oregon. Our coils contain approximately 34.2% recycled steel. Approximately 19.8% is Post-consumer content, while Pre-consumer content is approximately 14.4%. R-studs are listed as "Red List Free" by the International Living Future Institute. Steel is one of the most sustainable building materials in the world. It is recycled content, recyclable, durable, safe, zinc-coated, dimensionally stable and strong, as well as not susceptible to rot, termites, or mold.

Supporting Documentation

- 2016 AISI - ASD, LRFD, and LSD
- 2012 AISI - ASD, LRFD, and LSD
- 2010 AISI - ASD, LRFD, and LSD
- 2007 AISI - ASD, LRFD, and LSD
- 2004 AISI - ASD, LRFD, and LSD
- 2001 AISI - ASD, LRFD, and LSD
- 1999 AISI - ASD and LRFD & 2002 ASCE - ASD and LRFD (stainless steel)

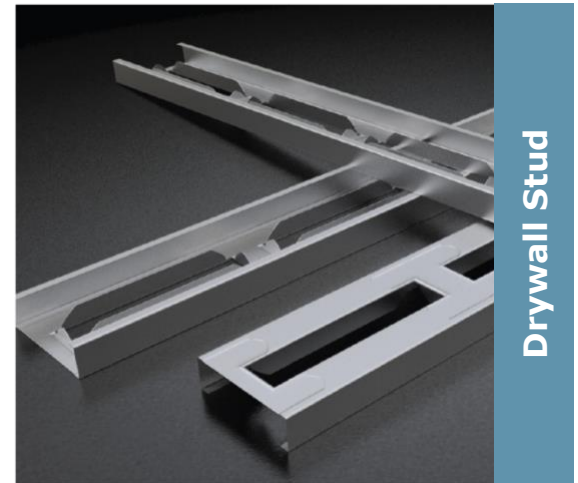

Drywall Stud

Web openings (not punch-outs) formed from web every 12 in. with Stamping at bridge every 12 in.

ASTM & Code Standards:

- ✓ ATI/Intertek CCRR 1073
- ✓ IBC 2012 Compliant
- ✓ AISI S-100 & S220-11
- ✓ ASTM E119, E72, E90
- ✓ ASTM AC86, C645, & C745
- ✓ UL 263

<p>Project Information</p> <p>Name: Address:</p>	<p>Contractor Information</p> <p>Name: Contact: Phone: Fax:</p>	<p>Architect Information</p> <p>Name: Contact: Phone: Fax:</p>
---	--	---

Product category: R-stud 19 mil Drywall Stud
Product name: 400RS162-19 50Ksi G60
4" x 1-5/8" R-stud

Limiting Wall Heights

Spacing (inches)	5 psf			7.5 psf			10 psf		
	L/120	L/240	L/360	L/120	L/240	L/360	L/120	L/240	L/360
12									
16	24'1"	19'1"	16'8"	21'10"	16'8"	14'7"	19'10"	15'2"	13'3"
24	21'0"	17'8"	14'7"	19'1"	14'7"	13'3"	16'8"	13'3"	11'7"

Table Notes:

- Allowable composite limiting heights were determined from AC86-2012 testing by Intertek Testing / Architectural Testing, Inc.
- The composite limiting heights tables provided above are based on a single layer of Type X gypsum board from the following manufacturers, American, CertainTeed, Georgia Pacific, National, PABCO, and USG.
- The gypsum is to be applied full height in the vertical orientation to each stud flange and installed in accordance with ASTM C754-2004 using a minimum of No. 6 Type S Drywall spaced as listed below:
 - Screws spaced a minimum of 16 inches on-center to framing members spaced at 12 or 16 inches on-center.
 - Screws spaced a minimum of 12 inches on-center to framing members spaced at 24 inches on-center.
- No fasteners are required for attaching the stud to the track except as detailed in ASTM C754-2008.

Profile

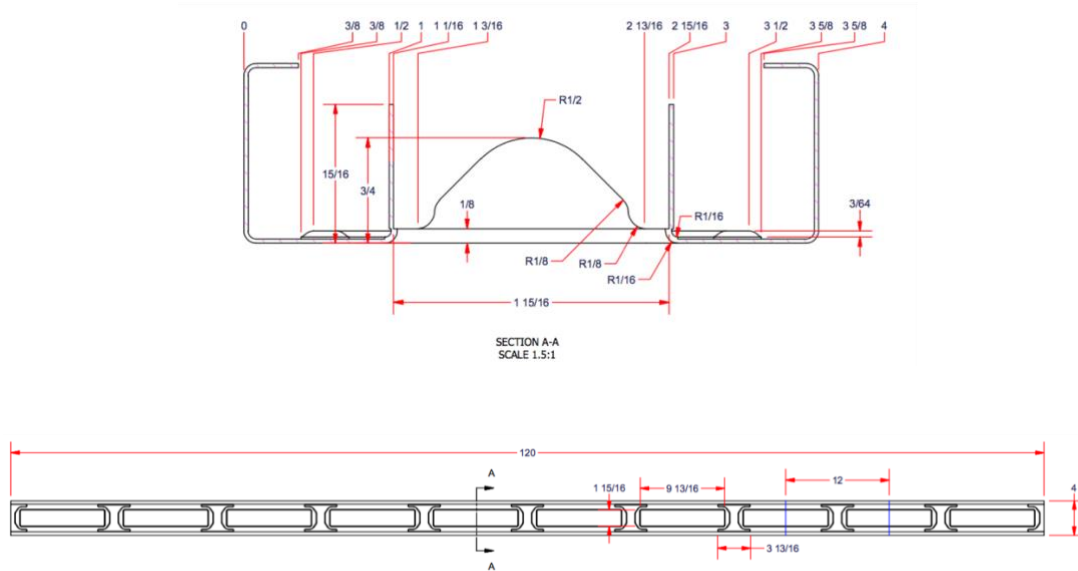

Project Information

Name:
Address:

Contractor Information

Name:
Contact:
Phone:
Fax:

Architect Information

Name:
Contact:
Phone:
Fax: