

**Product category:** R-stud 33 mil Load Bearing Stud  
**Product name:** 400RS162-33 50 Ksi G60  
4" x 1-5/8" R-stud

Coating: G60  
Color coding: White

### Geometric Properties

Web depth	4.000 in	Weight	0.8851 lb/ft
Flange width	1.625 in	Web opening width	9-13/16 in
Stiffening lip	0.310 in	Web opening length	2-3/16 in
Design thickness	0.0346 in	Minimum thickness	0.0329 in
Yield stress, Fy	50 Ksi		

### Gross Section Properties of Full Section, Strong Axis\*

Cross sectional area (A)	0.26559 in <sup>2</sup>
Moment of inertia (Ix)	0.7069 in <sup>4</sup>
Radius of gyration (Rx, r1)	1.6314 in
Moment of inertia (Iy)	0.0779 in <sup>4</sup>
Radius of gyration (Ry, r2)	0.5416 in
Max bending moment Ix (Maxo)	9.7756 k-in
Max bending moment Iy (Mayo)	2.7151 k-in
Allowable shear force in web (Vax)	2.1845 k

### Tension/Compression Properties\*

Warping constant (Cw)	0.011635 in <sup>6</sup>
Distance from shear center to neutral axis (Xo)	-0.9620 in
Radii of gyration (Ro)	1.9699 in
Torsional flexural constant (Beta)	FEA-in <sup>4</sup>
Compression Pao (max)	6.3859 k
Tension Tao (Ta)	9.2955 k
Unbraced Length (Lu)	Full / Non-braced
Fully Braced Strength (CFS) *CFS result	

### Notes:

- Calculated properties are based on AISI S100-12, North American Specifications for Cold-Formed Steel Structure Members and ICC-ES AC46-2015, Acceptance Criteria for Cold-Formed Steel Framing Members.
- Effective properties herein incorporate the increased strength from cold working of the steel while forming. We only use 50Ksi coils.
- Tabulated gross properties, including torsional properties, are based on the added cross section properties of the web openings. R-studs do not have punch-outs.
- Allowable moment includes cold work of forming.
- Allowable moment is taken as the lowest value based on local or distortional buckling. Distortional buckling strength is based on K-phi=0
- For deflection calculations, use the effective moment of inertia.
- Web openings are every 12 inches and are 9-13/16 inches long with flanges being 0.94 inches tall and corners of the web openings enhanced.

**Sustainability:** R-stud sources its steel coils from American Suppliers, such as US Steel and NUCOR's California Steel Industries for rolling in our manufacturing facilities. Our coils contain approximately 34.2% recycled steel. Approximately 19.8% is Post-consumer content, while Pre-consumer content is approximately 14.4%. R-studs are listed as "Red List Free" by the International Living Future Institute. Steel is one of the most sustainable building materials in the world. It is recycled content, recyclable, durable, safe, zinc-coated, dimensionally stable and strong, as well as not susceptible to rot, termites, or mold.

### Supported Documentation

- 2016 AISI - ASD, LRFD, and LSD
- 2012 AISI - ASD, LRFD, and LSD
- 2010 AISI - ASD, LRFD, and LSD
- 2007 AISI - ASD, LRFD, and LSD
- 2004 AISI - ASD, LRFD, and LSD
- 2001 AISI - ASD, LRFD, and LSD
- 1999 AISI - ASD and LRFD & 2002 ASCE - ASD and LRFD (stainless steel)

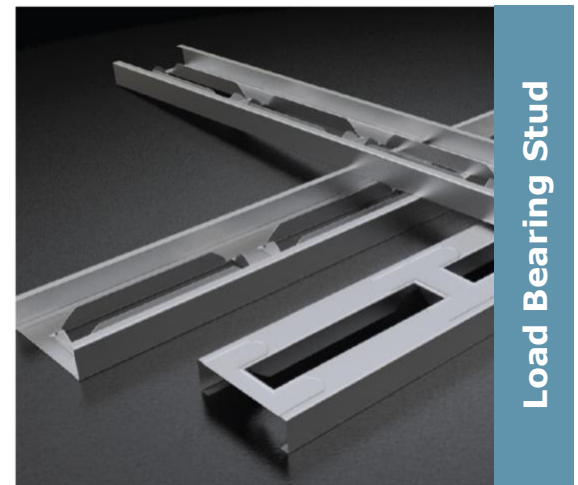

Web openings (not punch-outs) formed from web every 12 in. with Stamping at bridge every 12 in.

### ASTM & Code Standards:

- ✓ ICC-NTA ESR
- ✓ ICC-ES 4510
- ✓ IBC 2012 Compliant
- ✓ AISI S902-08 & S909-13
- ✓ AISI A370-17 & S100-12
- ✓ ASTM AC46, C645, & C745
- ✓ UL Two Hour Load Bearing Fire
- ✓ US, Canadian, and International Patents Issued

<p><b>Project Information</b></p> <p>Name: Address:</p>	<p><b>Contractor Information</b></p> <p>Name: Contact: Phone: Fax:</p>	<p><b>Architect Information</b></p> <p>Name: Contact: Phone: Fax:</p>
---	--	---

**Product category:** R-stud 33 mil Load Bearing Stud  
**Product name:** 400RS162-33 50Ksi G60  
4" x 1-5/8" R-Stud

## Limiting Wall Heights

Spacing (inches)	5 psf			7.5 psf			10 psf		
	L/120	L/240	L/360	L/120	L/240	L/360	L/120	L/240	L/360
16	26'4"	20'11"	18'3"	23'1"	18'3"	15'11"	20'11"	16'6"	14'6"
24	23'8"	18'9"	15'11"	20'9"	15'11"	13'10"	18'3"	13'11"	12'8"

### Table Notes:

- Allowable composite limiting heights were determined from AC86-2012 testing by Intertek Testing / Architectural Testing, Inc.
- The composite limiting heights tables provided above are based on a single layer of Type X gypsum board from the following manufacturers, American, CertainTeed, Georgia Pacific, National, PABCO, and USG.
- The gypsum is to be applied full height in the vertical orientation to each stud flange and installed in accordance with ASTM C754-2004 using a minimum of No. 6 Type S Drywall spaced as listed below:
  - Screws spaced a minimum of 16 inches on-center to framing members spaced at 12 or 16 inches on-center.
  - Screws spaced a minimum of 12 inches on-center to framing members spaced at 24 inches on-center.
- No fasteners are required for attaching the stud to the track except as detailed in ASTM C754-2008.

## Profile

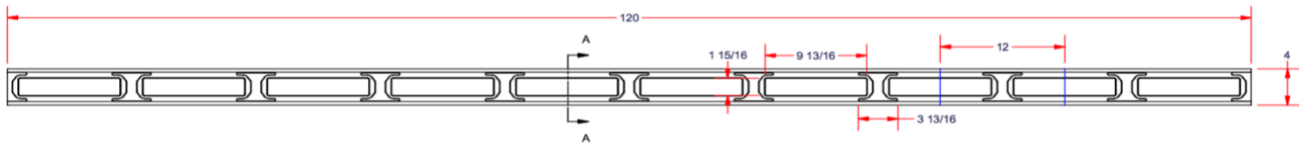
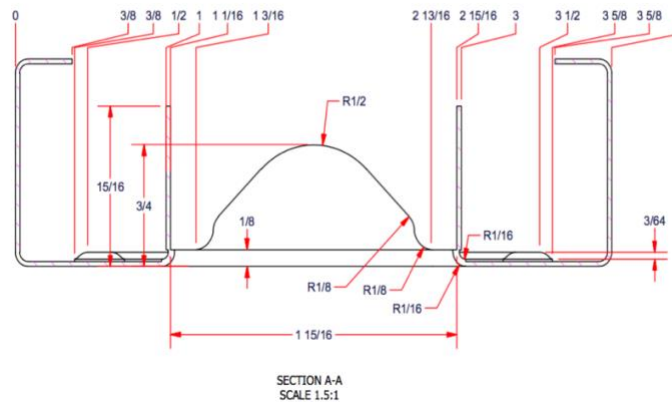

### Project Information

Name:  
Address:

### Contractor Information

Name:  
Contact:  
Phone:  
Fax:

### Architect Information

Name:  
Contact:  
Phone:  
Fax: